



Technology the world trusts

Whether you enjoy the thrill of water sports or just relaxing on your boat, choose the engine that helps you get more out of your time on the water.

Every engine in our range uses Yamaha's latest marine technologies, engine layouts and ingenious intake and exhaust systems - and our 4-stroke development has been so successful because, rather than just adapting ordinary automotive engines for the water, we design and build our marine-specification 4-strokes from scratch.

Without compromising on power, performance or usability, these specially designed engines also help preserve the environment with the use of pioneering clean-burn technologies.



- Ergonomic shift lever on the tiller handle
- Easy-fold tiller design for storage & portability
- Extra resting pad for convenient vertical storage
- Compact and efficient engine design
- Remarkable power and impressive torque
- Large comfortable-to-use carry handle
- Lighting coil fitted as standard
- Fresh water flushing system
- Shallow Water Drive for cruising close inshore
- Over-rev limiter
- Start-in-gear¹ protection system
- Audible warning of low oil pressure



Latest-generation engine design - efficiency and power

The F8 is a very compact and super-efficient engine design, with twin cylinder, SOHC (Single Overhead Camshaft) configuration. The stylish top cowling and graphics also reflect the modern design approach to be found on all our latest-generation engines.



Advanced tiller handle design and controls

For the F8, a fully ergonomic design approach has been adopted for the tiller handle and controls. The handle is a very convenient length and the shift lever is ideally positioned on the handle itself, within easy reach, for confident, relaxed control. The easy-fold-up handle arrangement makes carrying and storage very convenient.



True portability - and so easy to carry

The F8 is renowned for performance with true portability and features many design refinements which make it a real pleasure to use. The large, comfortable carry-handle is now integrated with the steering bracket - and the tiller handle folds neatly back to make it even more compact on the boat - and it's a great help for storage too.

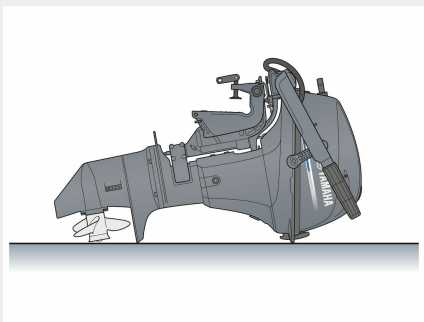

Rest pad for vertical storage position

This exciting engine features some other very practical refinements that make storage a breeze. The special rest-pad allows you to store the F8 vertically - or simply lie it on its back on the deck or floor - and with the new fold-back tiller handle, you can be sure that your outboard will be taking up less space on board or at home.

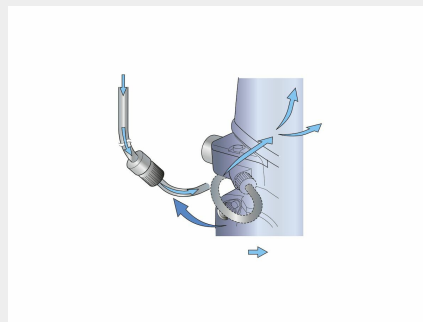

Fresh Water Flushing system

An easy-access, front-mounted connector allows you to easily flush salt and dirt from the waterways without having to run the engine: just connect a hose and you're ready to go. This is a very efficient way to reduce corrosion and extend the life of your outboard.

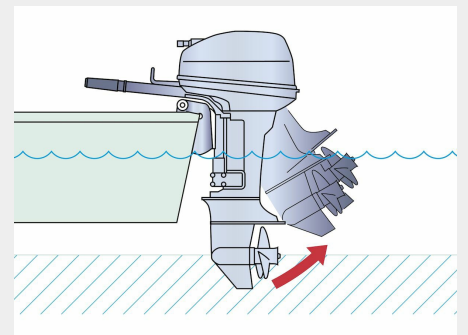

Shallow Water Drive system

Cruise towards the shore with confidence thanks to Yamaha's Shallow Water Drive system. Offering ample protection for your propeller, it allows you to get as close as you need to be, no matter whether you're cruising a murky lake or the crystal clear shallows of the sea.

Engine	
Engine type	4-stroke
Displacement	212 cm ³
No. of cylinders/Configuration	2/In-line, SOHC
Bore x stroke	56.0 mm x 43.0 mm
Prop shaft output at mid range	5.9 / 5,500 rpm
Full Throttle Operating Range	5,000 - 6,000 rpm
Lubrication system	Wet sump
Fuel Induction System	1-Carb
Ignition / advance system	CDI
Starter system	Manual
Gear ratio	2.08 (27:13)
Dimensions	
Transom height	S431L:558mm
Weight with propeller	F8FMHS: 40.0kg,F8FMHL: 41.0kg
Fuel tank capacity	separate, 12litres
Oil pan capacity	0.8litres
Additional Features	
Control	Tiller handle
Trim & Tilt method	Manual
Light coil / Alternator Output	12V -6Awith rectifier/regulator**
Propeller	Included
Remark	The kW data in this sheet is based on the ICOMIA 28 standard, measured at the prop shaft

All information in this catalogue is given for general guidance only and is subject to change without prior notice. Photographs may show boats being driven by professionals and no recommendation or guidance in respect of safe operation or style of use is intended or implied by the publication of these images. Always respect the local maritime regulations. Always wear the recommended personal flotation device and safety equipment when boating.